

Installation instructions

KIT K62

ENGLISH

ITALIANO

FRANÇAIS

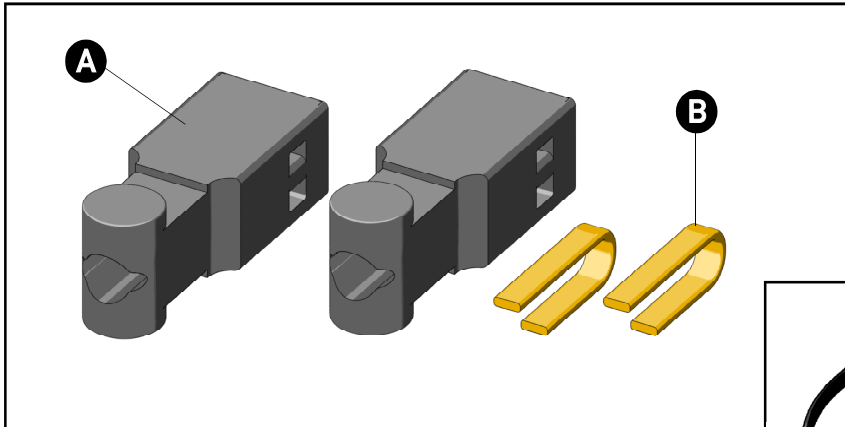

REF	KIT K62
A	2 connectors
B	2 split pins

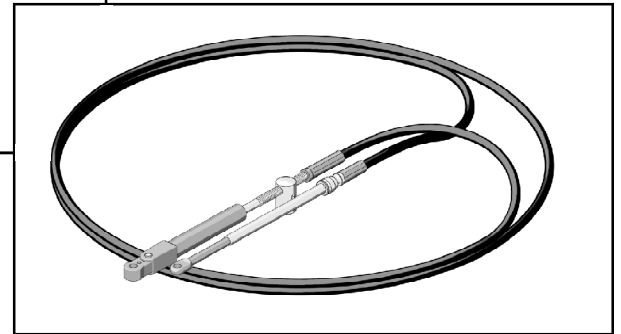

KIT K62 FOR ULTRAFLEX CABLES C36 AND MACH36

WARNING

THE FOLLOWING INSTRUCTIONS CONTAIN IMPORTANT SAFETY INFORMATION AND MUST BE FORWARDED TO THE OWNER OF THE BOAT.

ULTRAFLEX ^{CE}



PARTNER



UK
page. 2

I
pag. 9

F
page. 17

Dear Customer,

We would like to thank you for choosing an **ULTRAFLEX** product.

ULTRAFLEX has been a leader in steering systems for pleasure and professional boats for many years. **ULTRAFLEX** production is since ever synonymous of reliability and safety.

All **ULTRAFLEX** products are designed and manufactured to ensure the best performance. To ensure your safety and to maintain a high quality level, **ULTRAFLEX** products are guaranteed only if they are used with original spare parts.

ULTRAFLEX and **UFLEX** Quality Management Systems are certified CISQ-IQNet by the Italian Shipping Registry (RINA), in conformity with the UNI EN ISO 9001:2008 rule. **ULTRAFLEX** certification No. 6669/02/S (former 420/96). **UFLEX** certification No. 8875/03/S.

The quality management system involves all the company resources and processes starting from the design, in order to:

- ensure product quality to the customer;
- maintain and improve the quality standards constantly;
- pursue a continuous process improvement to meet the market needs and to increase the customer satisfaction

ULTRAFLEX Environmental Management System is certified CISQ-IQNet by the Italian Shipping Registry (RINA), in conformity with the UNI EN ISO 14001 rule. **ULTRAFLEX** certification No. EMS-1282/S.

Products for pleasure boats are constantly tested to check their conformity with the 2013/53/EU.



"**ULTRAFLEX** has over 80 years of experience in the marine industry and is a world leader in the production of mechanical, hydraulic and electronic steering systems, control boxes and steering wheels for any kind of pleasure, fishing or commercial boats.

The key factors which explain the increasing success of our products all over the world are the reliability of our products and the before and after sale service, the quality of the company organization and of the human resources and the continuous spending in research and development".

TABLE OF CONTENTS





MANUAL USE AND SYMBOLS USED.....	3
INTRODUCTION.....	3
WARRANTY.....	4

INSTALLATION

1.1 NECESSARY TOOLS.....	4
1.2 CONNECTOR INSTALLATION.....	4
1.3 CONTROL CABLE POSITIONING.....	5
1.3.1 SHIFT CABLE CONNECTION.....	5
1.3.2 THROTTLE CABLE CONNECTION.....	7

MANUAL USE AND SYMBOLS USED

THE INSTALLATION AND MAINTENANCE MANUAL is the document accompanying the product from its sale to its replacement and discharge. The manual is an important part of the product itself. It is necessary to read carefully the manual, before ANY ACTIVITY involving the product, handling and unloading included. In this manual the following symbols are used to ensure the user safety and to guarantee the correct operation of the product:

 DANGER	➔	Immediate hazards which CAUSE severe personal injury or death.
 WARNING	➔	Denotes that a hazard exists which can result in injury or death if proper precautions are not taken.
 CAUTION	➔	Denotes a reminder of safety practices or directs attention to unsafe practices which could result in personal injury or damage to the craft or components or to the environment.
NOTICE	➔	Important information for the correct installation and for maintenance, that does not cause any damage.
	➔	The symbol aside indicates all the operations which must be carried out by qualified or skilled staff, in order to avoid hazards. We recommend training the staff in charge of the product installation and checking their knowledge.

INTRODUCTION

This installation and maintenance manual represents an important part of the product and must be available to the people in charge of its use and maintenance.

The user must know the content of this manual.

ULTRAFLEX declines all responsibility for possible mistakes in this manual due to printing errors.

Apart from the essential features of the described product, **ULTRAFLEX** reserves the right to make those modifications, such as descriptions, details and illustrations, that are considered to be suitable for its improvement, or for design or sales requirements, at any moment and without being obliged to update this publication.

ALL RIGHTS ARE RESERVED. Publishing rights, trademarks, part numbers and photographs of **ULTRAFLEX** products contained in this manual are **ULTRAFLEX** property.

Great care has been taken in collecting and checking the documentation contained in this manual to make it as complete and comprehensible as possible. Nothing contained in this manual can be interpreted as warranty either expressed or implied - including, not in a restricted way, the suitability warranty for any special purpose. Nothing contained in this manual can be interpreted as a modification or confirmation of the terms of any purchase contract.

WARNING

To ensure the correct product and component operation, the product must be installed by qualified staff. In case of part damage or malfunction, please contact the qualified staff or our Technical Assistance Service.

<p>UFLEX S.r.l. Via Milite Ignoto,8A 16012 Busalla (GE)-Italy Tel: +39.010.962.0239 (Italy) Tel: +39.010.962.0244 (abroad) Fax: +39.010.962.0333 Email: ut@ultraflexgroup.it www.ultraflexgroup.it</p>	<p>TECHNICAL ASSISTANCE SERVICE</p> <p>North - South - Central America: UFLEX USA 6442 Parkland Drive Sarasota, FL 34243 Tel: +1.941.351.2628 Fax: +1.941.360.9171 Email: uflex@uflexusa.com www.uflexusa.com</p>
---	--



WARRANTY

ENGLISH

ULTRAFLEX guarantees that its products are well designed and free from manufacturing and material defects, for a period of two years from the date of manufacturing.

For the products which are installed and used on working or commercial boats the warranty is limited to one year from the date of manufacturing.

If during this period the product proves to be defective due to improper materials and/or manufacture, the manufacturer will repair or replace the defective parts free of charge.

Direct or indirect damage is not covered by this warranty. In particular the company is not responsible and this warranty will not cover the damage resulting from incorrect installation or use of the product (except for replacement or repair of defective parts according to the conditions and terms above).

This warranty does not cover the products installed on race boats or boats used in competitions.

The descriptions and illustrations contained in this manual should be used as general reference only.

For any further information please contact our Technical Assistance Service.

ULTRAFLEX steering system components are marked **CE** according to the Directive 2013/53/EU.

We remind you that only **CE** marked steering systems must be used on the boats marked **CE**. We inform you that the **ULTRAFLEX** warranty is null if some **ULTRAFLEX** components are installed on a steering system together with products of other brands.

1 INSTALLATION

1.1 Necessary tools



Phillips screwdriver



Pliers



Open end wrench
8mm [0.31"]



Socket wrench
17mm [0.66"]

1.2 Connector installation



1 Insert the connector (1) in the way shown in the picture, bringing it into contact with the cable fitting (2).

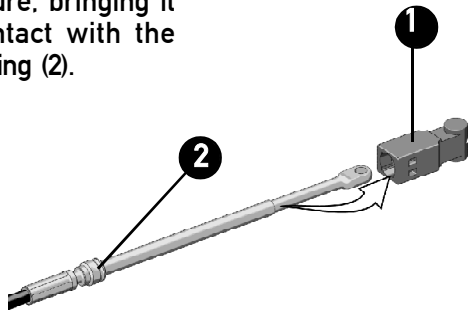

2 Lock the connector inserting the split pin (3) into the slots (A) and (B) and fold their ends.

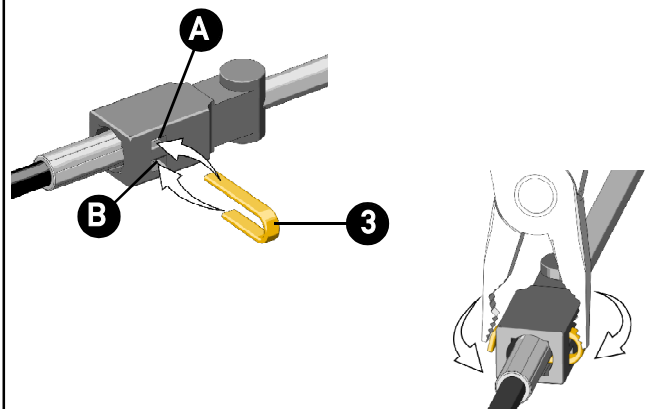



1.3 Control cable positioning

- 1 Select a direct path with a minimum number of bends and without any obstacles.

⚠ WARNING

Avoid too narrow bends (the minimum bend radius is 203 mm (8")).

NOTICE

Outboard engine installations require an additional length of about 120 cm (47") of the cables to allow engine swing.

The cables can be sustained by means of suitable cable hangers (supplied separately) or routed through segments of conduits (supplied separately too) for long straight runs.

⚠ WARNING

To avoid the control hardening, do not fix the cables near the control outlet (the minimum fixing distance is 500 mm) and in any case do not use fixing systems that can deform the casing.

2 CONTROL B301:

Remove the rear cover (4) of the control by unscrewing the screws (5) so as to reach easily the elements where the cables are to be fixed.

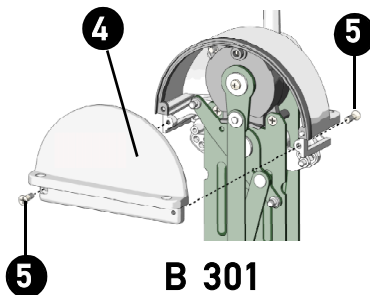

B 301

CONTROL B302:

Split the two boxes (6) by removing the screws (5).

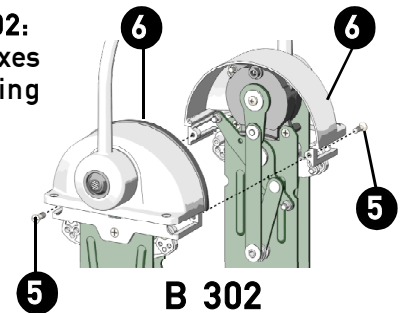

B 302

1.3.1 Shift cable connection

- 1 Place the control box on a level (the Ultraflex symbol on the lever will be turned upside down). Remove the cable clamp (7) from the plate (8) loosening the screws (9).

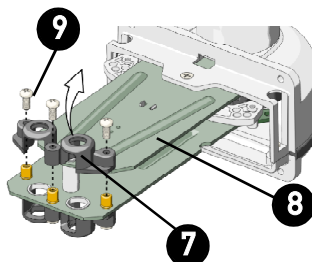

- 2 Mount the cable making sure the cylinder of the cable (10) is placed inside the plate hole (11).

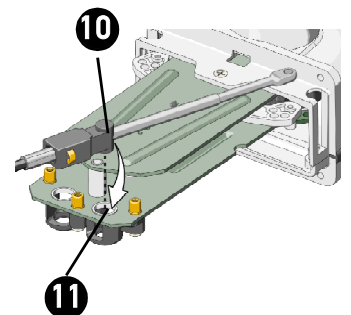

- 3 Remount the cable clamp (7) on the plate (8) aligning the cylinder of the connector (10) with the hole of the cable clamp.

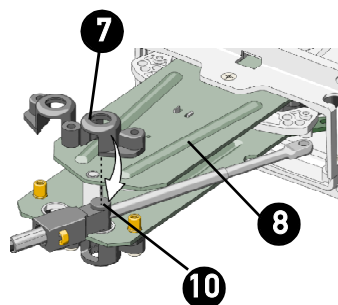

- 4 Fix the cable clamp (7) to the plate (8) with the screws (9).

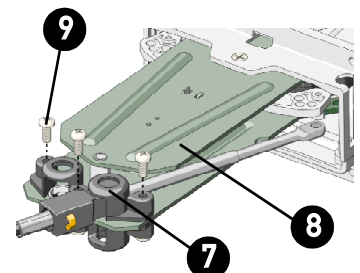

5 Measure on the engine the shift lever stroke from the forward gear to the reverse gear. See the possible strokes on the control device and select the nearest one; for instance, if the stroke on the engine from one end of stroke to the other is 67 mm, the cable must be connected to the more internal hole (68 mm stroke). If a stroke of 70 mm is detected, check if the 68 mm stroke is sufficient otherwise connect the cable to the central hole (76 mm stroke); some millimeters (5-6) of surplus stroke on the control device are counterbalanced by the cable play.

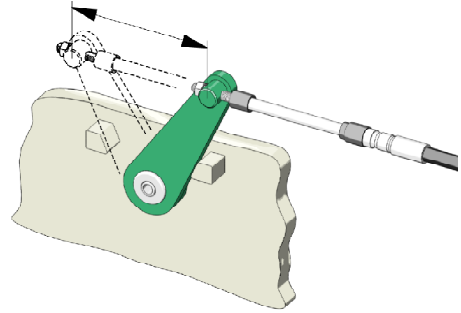

6 Turn upside down the control box (internal mechanism turned upside). Put the pin (12) on one of the three holes (a), (b), or (c) of the lever (13).

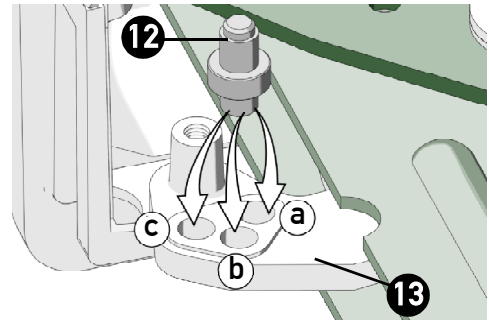
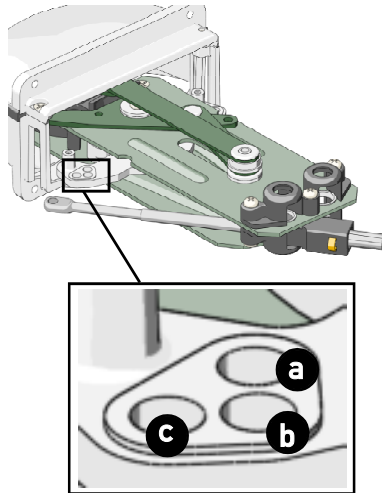

NOTICE

The hole is chosen according to the stroke of the cable (see the table below).

HOLE	a	b	c
STROKE [mm]	68	76	82

⚠ WARNING

Adjust the control cable stroke of the shift so as not to force the end of strokes of the engine lever. The non-compliance with this recommendation causes the control system malfunction such as:

- High resistance to the lever operation
- Early wear of the mechanism that can cause its locking.

7 Engage the rod (14) on the pin (12)

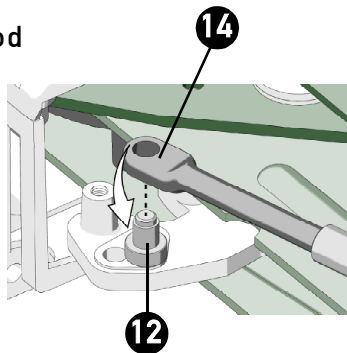

8 Mount the plate (15) in the way shown in the picture and fix it with the screw (16) on the hole (17).

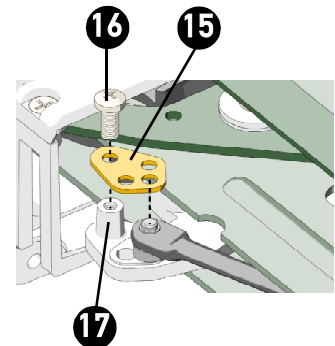

⚠ WARNING

Check the right adjustment of the shift stroke and make sure the following condition is complied with:

During the shift enabling the lever movement must always be smooth and it must have a constant resistance coming up against no resistance when the lever is turned as a throttle. Otherwise check the stroke correspondence between the control and the shift on the engine.



1.3.2 Throttle cable connection

1 Remove the cable clamp (7) from the plate (8) loosening the screws (9).

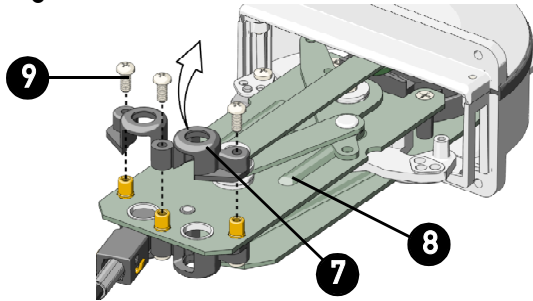

2 Mount the cable making sure the cylinder of the cable (10) is placed inside the plate hole (18).

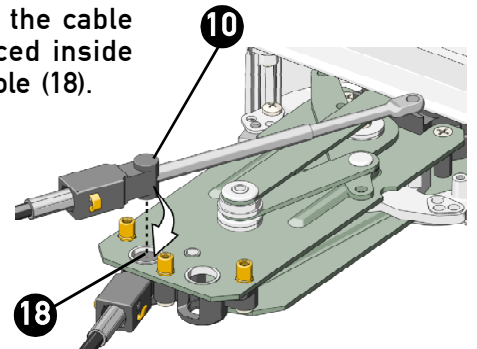

3 Remount the cable clamp (7) on the plate (8) aligning the cylinder of the cable (10) with the hole of the cable clamp. Fix the cable clamp to the plate with the screws (9).

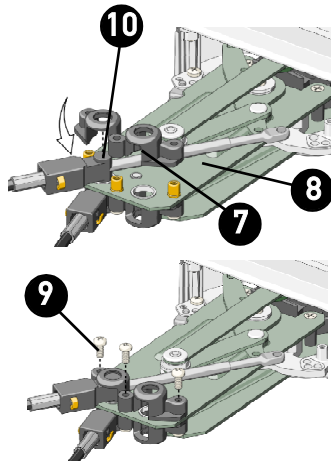

4 Engage the rod (19) on the pin (20).

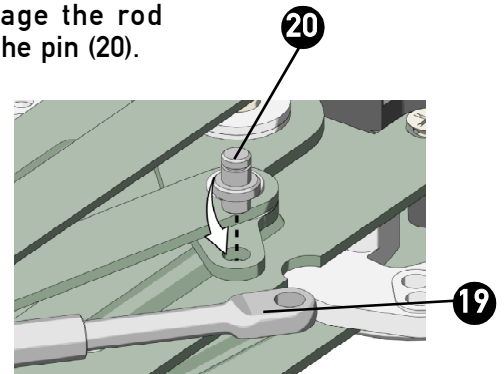

5 Fix the cable inserting the snap ring (21) in the groove of the pin (20).

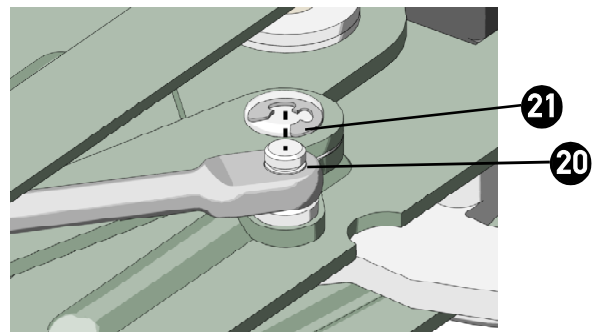

Istruzioni di montaggio

KIT K62

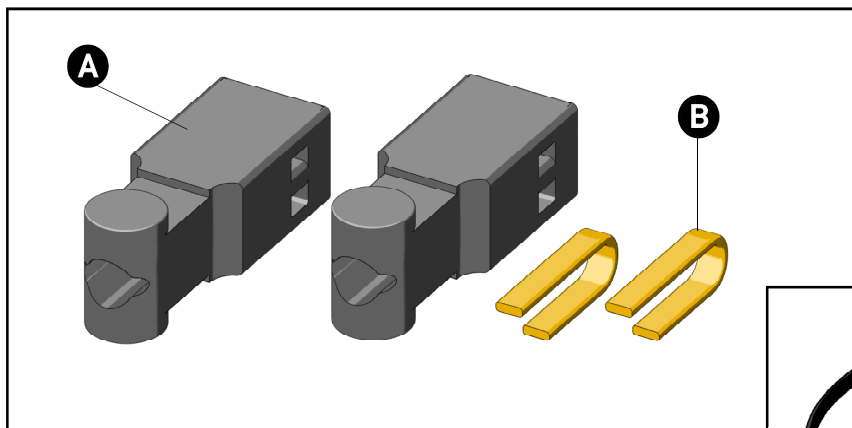

RIF	KIT K62
A	2 connettori
B	2 coppie

KIT K62 PER CAVI ULTRAFLEX C36 E MACH36

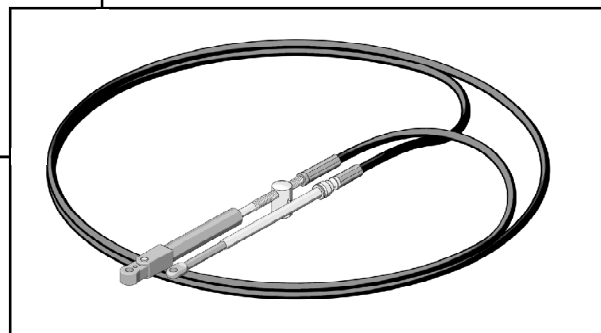

ITALIANO

⚠ AVVERTENZA

QUESTE ISTRUZIONI CONTENGONO INFORMAZIONI IMPORTANTI PER LA SICUREZZA E DEVONO ESSERE CONSEGNATE AL PROPRIETARIO DELL'IMBARCAZIONE.

CE



ULTRAFLEX



SOCIO



Gentile Cliente,

La ringraziamo per aver scelto un prodotto **ULTRAFLEX**.

ULTRAFLEX è da anni un punto di riferimento nei sistemi di guida nel settore della nautica da diporto e professionale.

Da sempre la produzione **ULTRAFLEX** è sinonimo di grande affidabilità e sicurezza.

Tutti i prodotti **ULTRAFLEX** sono progettati e prodotti per garantire sempre le prestazioni migliori, relativamente allo scopo per cui sono concepiti.

Per tutelare la Vostra sicurezza e per mantenere sempre un alto livello qualitativo **ULTRAFLEX** garantisce i propri prodotti solo se utilizzati con i ricambi originali.

I Sistemi di Gestione Qualità **ULTRAFLEX** ed **UFLEX** sono certificati CISQ-IQNet dal RINA Registro Italiano Navale, in conformità alla Norma UNI EN ISO 9001:2008. Certificato **ULTRAFLEX** n° 6669/02/S (già 420/96). Certificato **UFLEX** n°8875/03/S.

Il sistema Qualità coinvolge tutte le risorse ed i processi aziendali a partire dalla progettazione, per:

- garantire al cliente la qualità del prodotto;
- impostare le azioni per mantenere e migliorare nel tempo gli standard di qualità;
- perseguire un continuo miglioramento dell'efficacia e dell'efficienza dei processi per poter essere sempre in sintonia con le esigenze del mercato ed accrescere la soddisfazione dei Clienti.

Il sistema di Gestione Ambientale Ultraflex è certificato da CISQ-IQNet dal RINA Registro Italiano Navale, in conformità alla Norma UNI EN ISO 14001. Certificato **ULTRAFLEX** n° EMS-1282/S.

I prodotti destinati alla nautica da diporto vengono costantemente controllati per verificare la rispondenza ai requisiti imposti dalla direttiva 2013/53/UE.



"**ULTRAFLEX**, con più di 80 anni di esperienza nel settore nautico è oggi leader globale nella produzione di sistemi di guida meccanici, idraulici ed elettronici, scatole di comando e volanti per imbarcazioni a motore da diporto, da pesca o da lavoro di ogni dimensione e tipo di motorizzazione.

L'affidabilità dei nostri prodotti ed il servizio ante e post vendita, la qualità dell'organizzazione aziendale e delle risorse umane insieme agli investimenti continui in ricerca e sviluppo sono fattori determinanti per spiegare il successo crescente dei nostri prodotti ovunque nel mondo".

INDICE

USO DEL MANUALE E SIMBOLOGIA IMPIEGATA.....	11
LETTERA INFORMATIVA.....	11
GARANZIA.....	12

INSTALLAZIONE

1.1 UTENSILI NECESSARI.....	12
1.2 INSTALLAZIONE DEL CONNETTORE SUL CAVO.....	12
1.3 POSIZIONAMENTO DEI CAVI DI CONTROLLO.....	13
1.3.1 COLLEGAMENTO DEL CAVO PER IL CONTROLLO DELL'INVERTITORE.....	13
1.3.2 COLLEGAMENTO DEL CAVO PER IL CONTROLLO DEL GAS.....	15

ULTRAFLEX S.p.A.

16015 Casella (Genova) Italia - Via Crose, 2

USO DEL MANUALE E SIMBOLOGIA IMPIEGATA

IL MANUALE DI INSTALLAZIONE E MANUTENZIONE è il documento che accompagna il prodotto dal momento della sua vendita fino alla sua sostituzione e smaltimento. Risulta cioè essere parte integrante dello stesso.

E' richiesta la lettura del manuale prima che venga intrapresa **QUALSIASI ATTIVITA'** che coinvolga il prodotto compresa la movimentazione e lo scarico dello stesso dal mezzo di trasporto. Al fine di tutelare la sicurezza dell'utilizzatore e per garantire il corretto funzionamento del prodotto nel presente manuale è stata adottata la simbologia di seguito descritta.

▲ PERICOLO

Danni immediati che **CAUSANO** ferite gravi alla persona o che portano alla morte.

▲ AVVERTENZA

Indica che esiste un pericolo che può causare lesione o morte se non sono adottate le precauzioni appropriate.

▲ ATTENZIONE

Indica un richiamo all'applicazione di pratiche di sicurezza oppure richiama l'attenzione su pratiche non sicure che potrebbero causare lesione personale o danno all'imbarcazione o ai componenti o all'ambiente.

NOTA

Informazione ritenuta importante per una installazione adeguata e per la manutenzione, che non è causa di danni.



Le operazioni per la cui esecuzione si richiede, onde evitare possibili rischi, personale qualificato o specializzato sono evidenziate con il simbolo indicato a lato. Si raccomanda di formare il personale destinato all'installazione del prodotto e di verificare che quanto previsto sia compreso ed attuato.

LETTERA INFORMATIVA

Il presente manuale di installazione e manutenzione costituisce parte integrante del prodotto e deve essere facilmente reperibile dal personale addetto all'uso e alla manutenzione dello stesso.

L'utilizzatore è tenuto a conoscere il contenuto del presente manuale.

ULTRAFLEX declina ogni responsabilità per eventuali inesattezze dovute ad errori di stampa, contenute nel manuale. Ferme restando le caratteristiche essenziali del prodotto descritto, **ULTRAFLEX** si riserva il diritto di apportare eventuali modifiche di descrizioni, dettagli e illustrazioni, che riterrà opportuno per il miglioramento dello stesso, o per esigenze di carattere costruttivo o commerciale, in qualunque momento e senza impegnarsi ad aggiornare tempestivamente questa pubblicazione. **TUTTI I DIRITTI SONO RISERVATI.** I diritti di pubblicazione, i marchi, le sigle e le fotografie dei prodotti **ULTRAFLEX** presenti in questo manuale sono di proprietà **ULTRAFLEX** che ne vieta qualsiasi riproduzione anche parziale. Ogni cura è stata posta nella raccolta e nella verifica della documentazione per rendere questo manuale il più completo e comprensibile possibile. Nulla di quanto contenuto nella presente pubblicazione può essere interpretato come garanzia o condizione espressa o implicita - inclusa, non in via limitativa, la garanzia di idoneità per un particolare scopo. Nulla di quanto contenuto nella presente pubblicazione può inoltre essere interpretato come modifica o asserzione dei termini di qualsivoglia contratto di acquisto.

▲ AVVERTENZA

Al fine di assicurare il corretto funzionamento del prodotto e dei suoi componenti, lo stesso deve essere installato da personale esperto. In caso di rotture di parti componenti o malfunzionamento, rivolgersi al personale specializzato o contattare il nostro Servizio Assistenza Tecnica.

UFLEX S.r.l.

Via Milite Ignoto,8A
16012 Busalla (GE)-Italia
Tel: +39.010.962.0239 (Italia)
Tel: +39.010.962.0244 (Estero)
Fax: +39.010.962.0333
Email: ut@ultraflexgroup.it
www.ultraflexgroup.it

SERVIZIO ASSISTENZA TECNICA**Nord - Sud - Centro America:****UFLEX USA**

6442 Parkland Drive
Sarasota, FL 34243
Tel: +1.941.351.2628
Fax: +1.941.360.9171
Email: uflex@uflexusa.com
www.uflexusa.com



GARANZIA

ULTRAFLEX garantisce che i suoi prodotti sono costruiti a regola d'arte e che sono privi di difetti di fabbricazione e di materiali.

Questa garanzia è valida per un periodo di due anni decorrenti dalla data di fabbricazione dei prodotti ad eccezione dei casi in cui questi siano installati ed usati su barche da lavoro o comunque su barche ad utilizzo commerciale, nel qual caso la garanzia è limitata ad 1 anno dalla data di fabbricazione.

Questa garanzia è limitata alla sostituzione o riparazione gratuita del pezzo che, entro il termine suddetto, ci sarà restituito in porto franco e che rileveremo essere effettivamente difettoso nei materiali o/e nella fabbricazione.

È escluso dalla garanzia ogni e qualsiasi altro danno diretto o indiretto. In particolare, è escluso dalla garanzia e da ogni nostra responsabilità (tranne quella di sostituire o riparare, nei termini e condizioni suddette, i pezzi difettosi) il malfunzionamento dei nostri prodotti qualora il loro mancato o difettoso funzionamento sia attribuibile ad una errata installazione o ad uso negligente o improprio.

Questa garanzia non copre i prodotti installati su barche da corsa o utilizzate in contesti competitivi. Le descrizioni e le illustrazioni di questo manuale s'intendono fornite a titolo indicativo.

Per informazioni dettagliate si prega di contattare il nostro Servizio Assistenza.

I componenti dei sistemi di guida **ULTRAFLEX** sono marcati **CE** come richiesto dalla direttiva 2013/53/UE.

Vi ricordiamo che sulle imbarcazioni marcate CE è obbligatorio installare sistemi di guida i cui componenti siano marcati CE. Vi informiamo che la garanzia **ULTRAFLEX** decade automaticamente qualora alcuni componenti **ULTRAFLEX** siano installati in un sistema di guida insieme a prodotti di altre marche.

ITALIANO

1 INSTALLAZIONE

1.1 Utensili necessari



Cacciavite a stella



Pinza



Chiave esagonale 8mm [0.31"]



Chiave a tubo 17mm [0.66"]

1.2 Installazione del connettore sul cavo



1 Inserire il connettore (1) nel verso indicato in figura, portandolo in battuta sul terminale guaina (2).

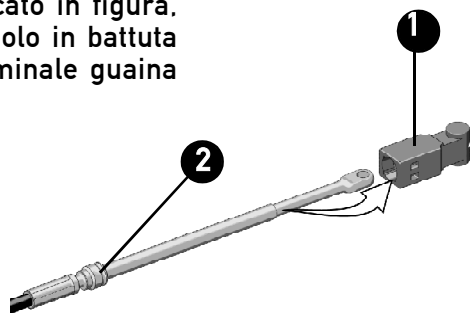

2 Bloccare il connettore inserendo la coppiglia (3) nelle feritoie (A) e (B) e ripiegare le estremità della stessa.

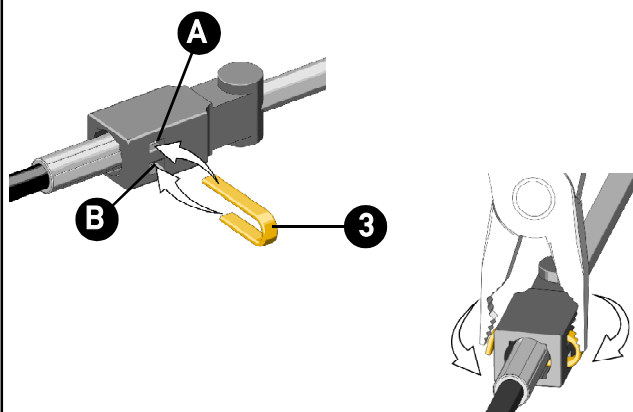



1.3 Posizionamento dei cavi di controllo

1 Stendere i cavi di comando secondo un percorso con il minor numero di curve e completamente libero da ostacoli.

⚠ AVVERTENZA

Evitare curvature troppo strette (raggio minimo di curvatura 203 mm (8")).

NOTA

Per le installazioni sui motori fuoribordo occorre lasciare ai cavi una lunghezza aggiuntiva di ca 120 cm (47") in modo da consentire i movimenti del motore.

I cavi possono essere vincolati per mezzo degli appositi cavallotti (forniti a parte) oppure facendoli passare attraverso segmenti di condotto (anch'essi forniti a parte) nei tratti lunghi e privi di curvature.

⚠ AVVERTENZA

Allo scopo di evitare indurimenti del comando, non fissare i cavi in prossimità dell'uscita dal comando stesso (distanza minima per il fissaggio 500 mm) e comunque non utilizzare sistemi di fissaggio che possano provocare deformazioni della guaina.

2 COMANDO B301:

Rimuovere il coperchio posteriore (4) della scatola di comando svitando le viti (5) in modo da avere pieno accesso agli elementi su cui andranno fissati i cavi.

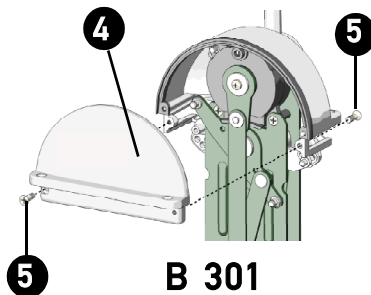

B 301

COMANDO B302:

Separare le due scatole (6), rimuovendo le viti (5).

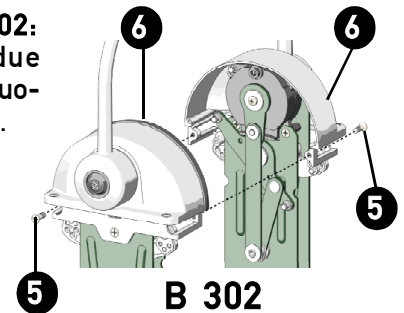

B 302

1.3.1 Collegamento del cavo per il controllo dell'invertitore

1 Collocare la scatola di comando su di un piano (il logo Ultraflex presente sul mozzo della leva sia rivolto verso l'alto). Rimuovere il fermaguaina (7) dalla piastra (8) svitando le viti (9).

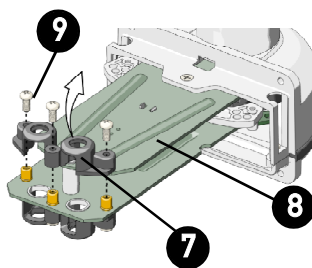

2 Collegare il cavo in modo che l'elemento cilindrico del connettore (10) sia calzato all'interno del foro (11) della piastra.

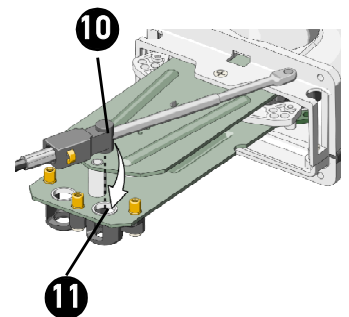

3 Ricollocare il fermaguaina (7) sulla piastra (8) allineando l'elemento cilindrico del connettore (10) con il foro del fermaguaina.

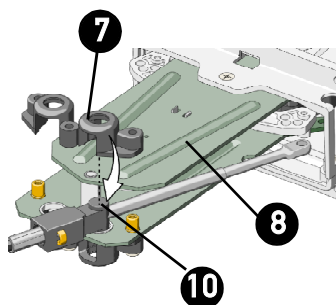

4 Assicurare il fermaguaina (7) alla piastra (8) serrando le viti (9).

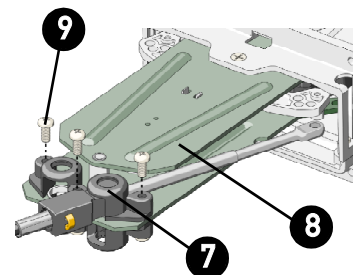

5 Misurare sul motore la corsa che compie la levetta dell'invertitore da marcia avanti a marcia indietro. Riferirsi alle corse disponibili sul meccanismo di comando e scegliere quella che piu' si avvicina; per esempio: se la corsa rilevata sul motore, da finecorsa a finecorsa risulta 67 mm, il cavo dovrà essere collegato al foro piu' interno (corsa 68 mm), nel caso si rilevi una corsa di 70 mm, verificare se sufficiente la corsa 68 mm sul meccanismo altrimenti connettere il cavo al foro centrale (corsa 76 mm); alcuni millimetri (5-6) di corsa in eccesso sul meccanismo di comando sono compensati dal gioco del cavo.

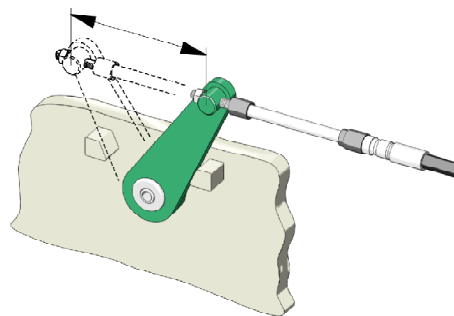

6 Capovolgere la scatola di comando (meccanismo interno rivolto verso l'alto). Inserire il perno (12) su uno dei fori (a), (b), o (c) presenti sul bilanciante invertitore della scatola di comando (13)

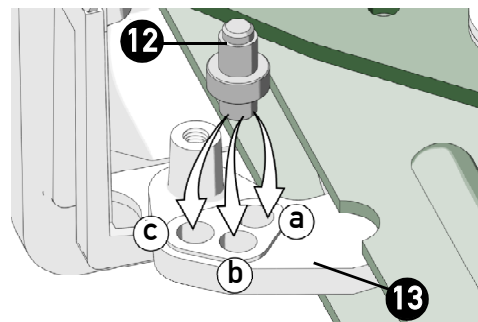
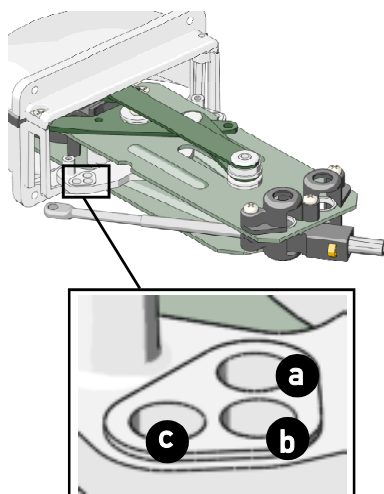

NOTA

Il foro viene scelto in funzione della corsa che si vuole far compiere al cavo; a tale scopo fare riferimento alla tabella riportata di seguito:

FORO	a	b	c
CORSA [mm]	68	76	82

⚠ AVVERTENZA

Regolare la corsa del cavo di comando dell'invertitore in modo da non generare forzature sui finecorsa della levetta sul motore.

L'inosservanza di questa raccomandazione causa malfunzionamenti del sistema di controllo, quali:

- Elevata resistenza all'azionamento della leva
- Precoce usura del meccanismo che può provocare il bloccaggio dello stesso.

7 Innestare l'astina (14) sul perno (12)

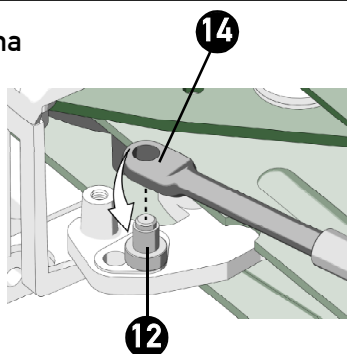

8 Montare la piastrina (15) nel verso mostrato in figura e bloccarla avvitando la vite (16) sul foro del perno (17) del bilanciante.

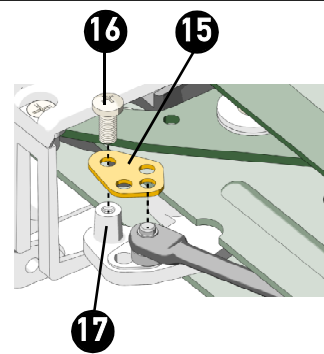

⚠ AVVERTENZA

Verificare la corretta regolazione della corsa dell'invertitore, accertandosi che sia rispettata la seguente condizione:

Durante l'innesto dell'invertitore il movimento della leva deve essere sempre fluido ed a resistenza costante e non deve incontrare nessuna resistenza continuando a ruotare la leva stessa in modalità di acceleratore. In caso contrario controllare la corrispondenza della corsa fra comando ed invertitore sul motore.



1.3.2 Collegamento del cavo per il controllo del gas

1 Rimuovere il fermaguaina (7) dalla piastra (8) svitando le viti (9).

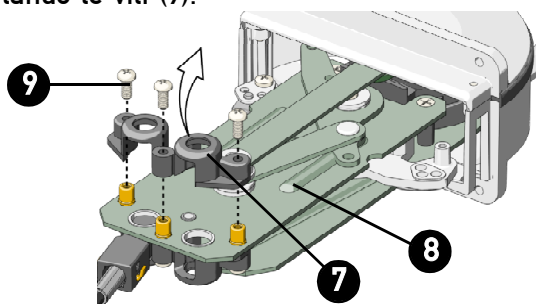

2 Posizionare il cavo in modo che l'elemento cilindrico del connettore (10) sia calzato all'interno del foro (18) della piastra.

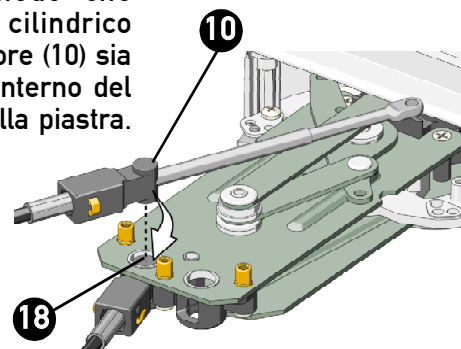

3 Ricollocare il fermaguaina (7) sulla piastra (8) allineando l'elemento cilindrico del connettore (10) con il foro del fermaguaina. Assicurare il fermaguaina alla piastra serrando le tre viti (9).

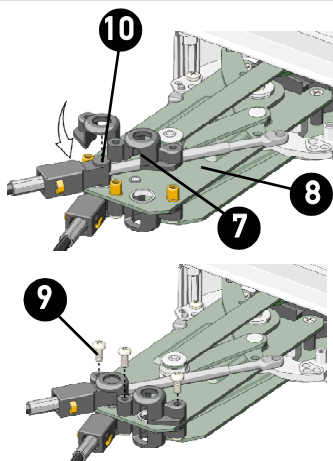

4 Innestare l'astina (19) sul perno (20).

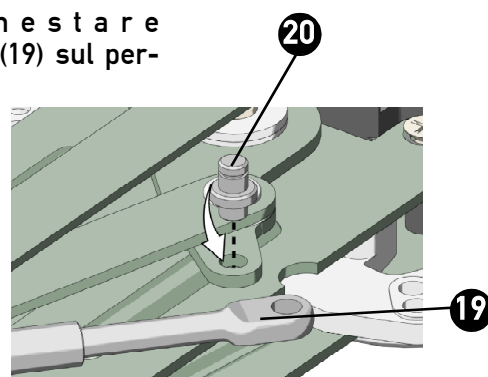

5 Assicurare il cavo mediante l'anello elastico (21) che va inserito nell'apposita sede ricavata sul perno (20).

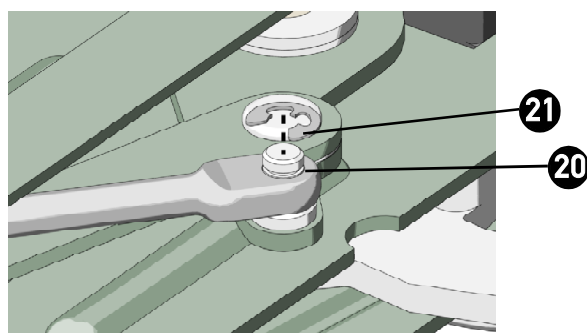

Instructions pour le montage

KIT K62

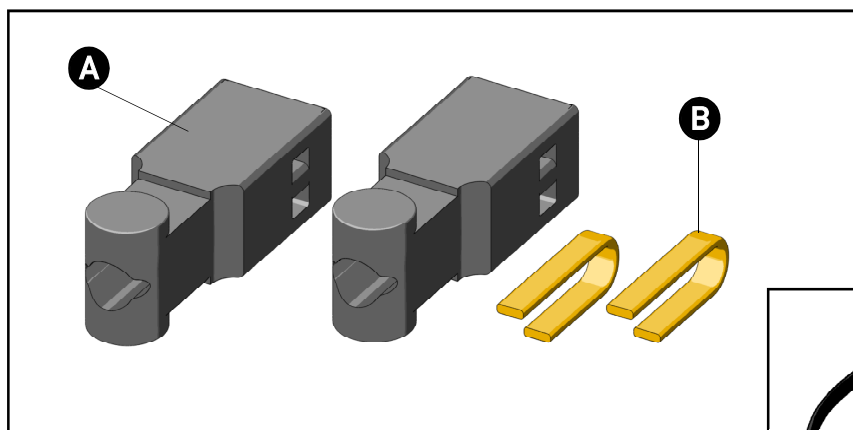

REF	KIT K62
A	2 connecteurs
B	2 goupilles

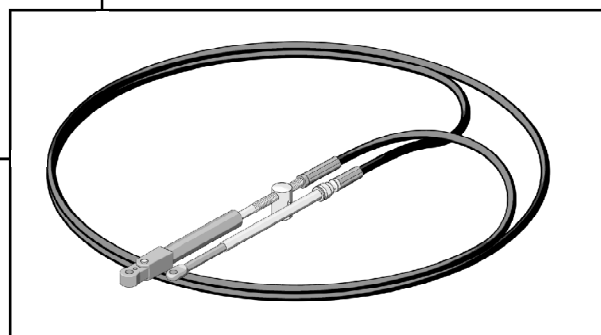

KIT K62 POUR CABLES ULTRAFLEX C36 ET MACH36

⚠ AVERTISSEMENT

CES INSTRUCTIONS CONTIENNENT DES INFORMATIONS IMPORTANTES POUR LA SECURITE ET ELLES DOIVENT ETRE DONNEES AU PROPRIETAIRE DU BATEAU.

FRANÇAIS

CE



ULTRAFLEX



ASSOCIE



ULTRAFLEX

Cher Client,

Nous vous remercions pour avoir choisi un produit **ULTRAFLEX**.

La Société **ULTRAFLEX** est depuis plusieurs années un point de repère dans les systèmes de gouvernement dans le domaine de la navigation de plaisance et professionnelle.
La production **ULTRAFLEX** est depuis toujours une garantie de grande fiabilité et sécurité.

Tous les produits **ULTRAFLEX** sont conçus et fabriqués pour assurer toujours les performances les meilleures.

Pour assurer votre sécurité et pour maintenir toujours un niveau de qualité élevé **ULTRAFLEX** ne garantit ses produits que si les pièces de rechange originales sont utilisées (voir annexe "Application Spare Parts").

Les Systèmes de Gestion de la Qualité **ULTRAFLEX** et **UFLEX** sont certifiés CISQ-IQNet par le Registre Italien des Navires (RINA), en conformité avec la Norme UNI EN ISO 9001:2008. Certificat **ULTRAFLEX** n° 6669/02/S (ancien 420/96). Certificat **UFLEX** n°8875/03/S.

Le système Qualité implique toutes les ressources et les processus d'entreprise à partir de la conception du projet au but de:

- assurer au client la qualité du produit;
- maintenir et améliorer continuellement les standard de qualité;
- poursuivre une amélioration continue de l'efficacité des processus afin de répondre toujours aux exigences du marché et d'augmenter la satisfaction des Clients;

Le système de Gestion Environnementale de la Qualité **ULTRAFLEX** est certifié CISQ-IQNet par le Registre Italien des Navires (RINA), en conformité avec la Norme UNI EN ISO 9001:2000. Certificat **ULTRAFLEX** n° EMS-1282/S.

Vérifier la conformité des produits aux prescriptions de la directive 2013/53/EU.



"**ULTRAFLEX** avec plus de 80 années d'expérience dans le domaine nautique, est aujourd'hui une industrie de pointe sur échelle mondiale dans la production de systèmes de gouvernement mécaniques, hydrauliques, électroniques, boîtes de commande et volants pour bateaux moteur de toutes dimensions pour la plaisance, la pêche ou le travail.

La fiabilité de nos produits et le service pré-vente et après-vente, la qualité de l'organisation de l'entreprise et des ressources humaines aussi bien que les investissements continus dans la recherche et le développement sont des facteurs fondamentaux pour expliquer le succès croissant de nos produits dans le monde entier".

INDEX

EMPLOI DU MANUEL ET SYMBOLES UTILISES.....	19
LETTRE D'INFORMATION.....	19
GARANTIE.....	20

INSTALLATION

1.1 OUTILS NECESSAIRES.....	20
1.2 INSTALLATION DU CONNECTEUR SUR LE CABLE.....	20
1.3 POSITIONNEMENT DES CABLES DE CONTROLE.....	21
1.3.1 CONNEXION DU CABLE POUR LE CONTROLE DE L'INVERSEUR.....	21
1.3.2 CONNEXION DU CABLE POUR LE CONTROLE DU GAZ.....	23









ULTRAFLEX S.p.A.

16015 Casella (Genova) Italia - Via Crose, 2

EMPLOI DU MANUEL ET SYMBOLES UTILISES

Le MANUEL D'INSTALLATION ET D'ENTRETIEN est le document qui accompagne le produit de sa vente jusqu'à son remplacement et sa démolition. C'est donc une partie fondamentale du manuel lui-même.

Il faut lire le manuel avant TOUTE ACTIVITE concernant le produit y compris sa manutention et son déchargement du moyen de transport. Les symboles ci-dessous ont été adoptés dans le manuel afin d'assurer la sécurité de l'utilisateur et le fonctionnement correct du produit.

 DANGER		Domages immédiats qui CAUSENT des blessures graves à la personne ou qui en provoquent la mort.
 AVERTISSEMENT		Il indique qu'il y a un danger qui peut provoquer des lésions ou la mort si on n'adopte pas les précautions appropriées.
 ATTENTION		Il indique un appel à l'application de pratiques de sécurité ou il appelle l'attention sur des pratiques non sûres qui pourraient causer des lésions personnelles ou des dommages au bateau ou aux composants ou à l'environnement.
NOTE		Information importante pour une installation adéquate et pour l'entretien, qui ne cause pas de dommages.
		Les opérations pour l'exécution desquelles on demande du personnel qualifié ou spécialisé, afin d'éviter toute sorte de risques, sont indiquées avec le symbole à côté. On recommande de former le personnel préposé à l'installation du produit et de vérifier si ce qui est prévu a été compris et mis en œuvre.

LETTRE D'INFORMATION

Ce manuel d'installation et d'entretien est une partie intégrante du produit et il doit être facilement repérable par le personnel préposé à son emploi et à son entretien.

L'utilisateur doit connaître le contenu de ce manuel.

La Société **ULTRAFLEX** décline toute responsabilité en cas d'inexactitudes dues à des fautes d'impression, contenues dans le manuel. Bien que les caractéristiques principales du type de produit décrit ne changent pas, la Société **ULTRAFLEX** se réserve le droit de modifier les descriptions, les détails et les illustrations qu'elle jugera nécessaires afin de l'améliorer, soit pour des exigences de caractère constructif ou commercial, dans n'importe quel moment et sans être obligé de mettre à jour le manuel tout de suite.

TOUS LES DROITS SONT RESERVES. Les droits de publication, les marques, les sigles et les photos des produits **ULTRAFLEX** contenus dans ce manuel appartiennent à la Société **ULTRAFLEX** qui en interdit toute sorte de reproduction même partielle. Tous les soins ont été pris pour rassembler et contrôler la documentation contenue dans ce manuel afin de le rendre le plus complet et le plus compréhensible possible. Rien de ce qui est contenu dans cette publication ne peut être interprété comme garantie ou condition explicite ou implicite - y compris, pas en voie limitative, la garantie d'aptitude pour un but particulier. Rien de ce qui est contenu dans cette publication ne peut être interprété comme modification ou assertion des termes de n'importe quel contrat d'achat.

AVERTISSEMENT

Le produit doit être installé par du personnel formé afin d'assurer son fonctionnement correct et celui de ses composants. En cas de rupture de parties ou de mauvais fonctionnement, s'adresser au personnel spécialisé ou contacter notre Service d'Assistance Technique.

UFLEX S.r.l.

Via Milite Ignoto,8A
16012 Busalla (GE)-Italie
Tél: +39.010.962.0239 (Italie)
Tél: +39.010.962.0244 (Etranger)
Fax: +39.010.962.0333
Email: ut@ultraflexgroup.it
www.ultraflexgroup.it

SERVICE ASSISTANCE TECHNIQUE

Amérique du nord - du sud - centrale:
UFLEX USA

6442 Parkland Drive
Sarasota, FL 34243
Tél: +1.941.351.2628
Fax: +1.941.360.9171
Email: uflex@uflexusa.com
www.uflexusa.com



GARANTIE

La Société **ULTRAFLEX** garantit que ses produits sont fabriqués à règles d'art et qu'ils n'ont aucun défaut de fabrication et de matériels.

Cette garantie a une validité de deux années à partir de la date de fabrication des produits à l'exception des cas où ils sont installés et utilisés sur des bateaux de travail ou de commerce, car alors la garantie est limitée à une année de la date de fabrication.

Dans le cas où, pendant cette période le produit s'avérerait défectueux à cause des matériaux utilisés ou/et présente des vices de fabrication, le fabricant le remplacera ou le réparera gratuitement.

Tout autre dommage direct ou indirect est exclu de la garantie. En particulier la Société constructrice n'est pas responsable et cette garantie ne couvre pas les dommages dérivant d'une installation incorrecte ou d'un emploi inadéquat ou abusif des produits (à l'exception du remplacement ou de la réparation des pièces défectueuses dans les termes et les délais susmentionnés).

Cette garantie ne couvre pas les produits installés sur des bateaux de course ou utilisés pour des compétitions. Les descriptions et les illustrations contenues dans ce manuel sont seulement à titre indicatif.

Pour toute information détaillée contacter notre Service d'Assistance.

Les composants des systèmes de conduite **ULTRAFLEX** sont pourvus de la marque **CE** en conformité avec la directive 2013/53/UE.

On rappelle que sur les bateaux pourvus de la marque CE il est obligatoire d'installer des systèmes de conduite dont les composants sont marqués CE. Nous vous informons que la garantie **ULTRAFLEX** échoit automatiquement au cas où certains composants **ULTRAFLEX** seraient installés dans un système de gouvernement avec des produits de marques différentes.

1 INSTALLATION

1.1 Outils nécessaires



Tournevis étoile



Pince



Clé hexagonale 8mm [0.31"]



Clé à tube 17mm [0.66"]

1.2 Installation du connecteur sur le câble



1 Insérer le connecteur (1) dans la direction indiquée dans la figure, en le plaçant en butée sur l'extrémité de la gaine (2).

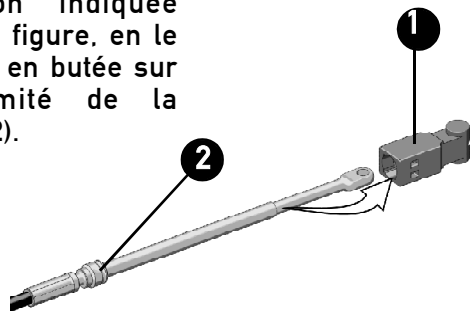

2 Bloquer le connecteur en insérant la goupille (3) dans les fentes (A) et (B) et replier les extrémités de celle-ci.

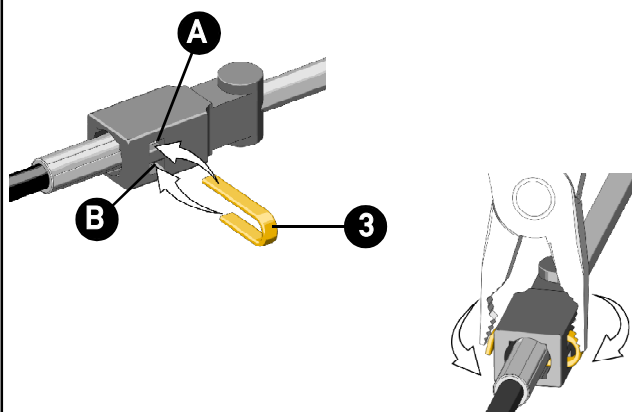



1.3 Positionnement des câbles de contrôle

- 1 Etendre les câbles de commande selon un parcours présentant le minimum de courbes et entièrement dépourvu d'obstacles.

⚠ AVERTISSEMENT

Eviter les courbes trop étroites (rayon de courbure minimum 203 mm (8")).

NOTE

Pour les installations sur des moteurs hors-bord laisser aux câbles une longueur supplémentaire d'environ 120 cm (47") de façon à permettre les mouvements du moteur.

Les câbles peuvent être fixés au moyen de crampillons (fournis séparément) ou en les faisant passer à travers des parties de conduit (fournis séparément eux aussi) dans les sections longues et sans courbes.

⚠ AVERTISSEMENT

Afin d'éviter toute sorte de durcissement de la commande ne pas fixer les câbles près de la sortie de la commande elle-même (distance minimum pour la fixation 500mm) et en tout cas n'utiliser aucun système de fixation qui pourrait déformer la gaine.

- 2 **COMMANDE B301:**
Enlever le couvercle postérieur (4) de la boîte de commande en dévissant les vis (5) de sorte à atteindre librement les éléments où les câbles seront fixés.

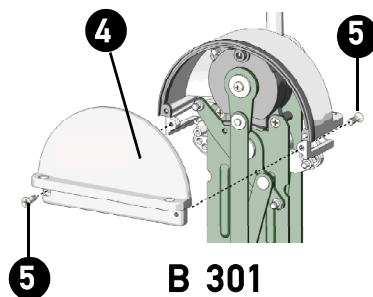

B 301

- COMMANDE B302:**
Séparer les deux boîtes (6), en enlevant les vis (5).

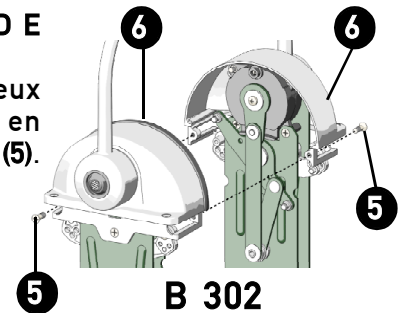

B 302

1.3.1 Connexion du câble pour le contrôle de l'inverseur

- 1 Positionner la boîte de commande sur une surface (le logo Ultraflex présent sur le moyeu du levier doit être vers le haut). Enlever la butée de gaine (7) de la plaque (8) en dévissant les vis (9).

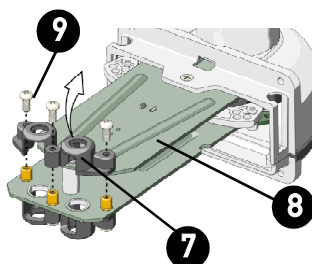

- 2 Connecter le câble de sorte que l'élément cylindrique du connecteur (10) soit placé à l'intérieur du trou (11) de la plaque.

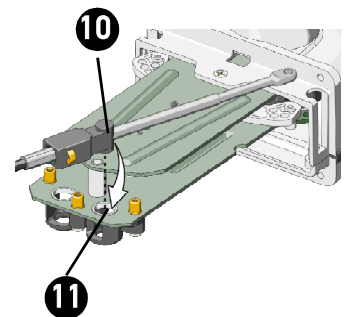

- 3 Repositionner la butée de gaine (7) sur la plaque (8) en alignant l'élément cylindrique du connecteur (10) avec le trou de la butée de gaine.

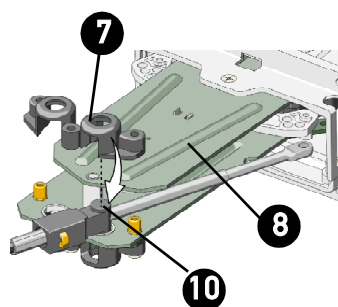

- 4 Fixer la butée de gaine (7) à la plaque (8) en serrant les vis (9).

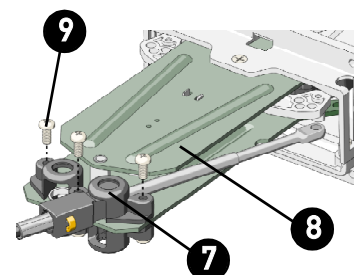

5 Mesurer sur le moteur la course du levier de l'inverseur de la marche avant à la marche arrière. Considérer les courses disponibles sur le mécanisme de commande et choisir la course la plus proche; par exemple si la course mesurée sur le moteur, d'un fin de course à l'autre est 67 mm, le câble devra être connecté au trou le plus intérieur (course 68 mm); au cas où une course de 70 mm serait mesurée, vérifier si la course de 68 mm sur le mécanisme est suffisante sinon connecter le câble au trou central (course 76 mm); quelques millimètres (5-6) de course excédentaire sur le mécanisme de commande sont compensés par le jeu du câble.

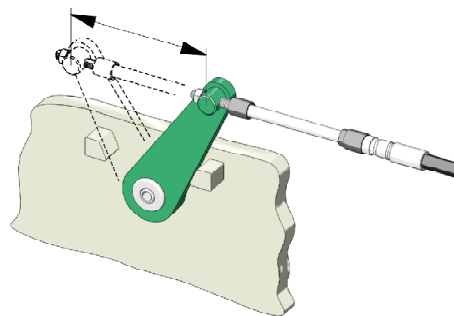

6 Renverser la boîte de commande (mécanisme intérieur tourné vers le haut). Insérer le pivot (12) dans un des trous (a), (b), ou (c) présents sur le balancier inverseur de la boîte de commande (13).

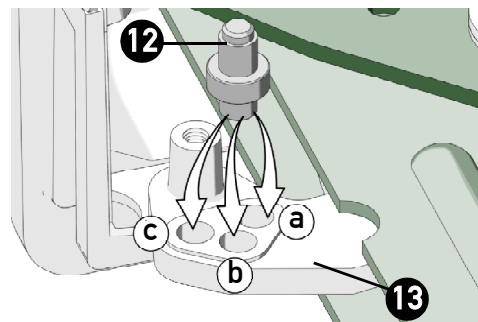
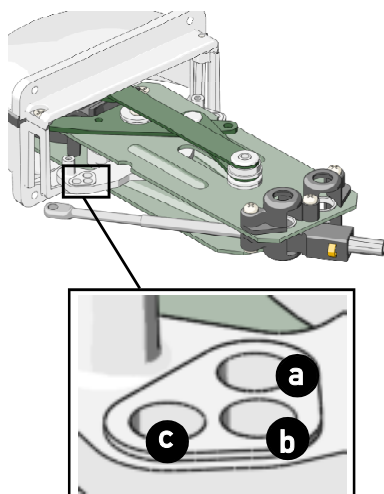

NOTE

Le trou est choisi en fonction de la course qu'on veut faire effectuer au câble (se référer au tableau à côté):

TROU	a	b	c
COURSE [mm]	68	76	82

⚠ AVERTISSEMENT

Régler la course du câble de commande de l'inverseur de sorte à ne pas produire de forçages sur les fins de course du levier sur le moteur.

La non-observation de cette recommandation cause des mauvais fonctionnements du système de contrôle, tels que:

- Résistance élevée lors de l'entraînement du levier
- Usure précoce du mécanisme qui peut provoquer son blocage.

7 Insérer la tige (14) dans le pivot (12).

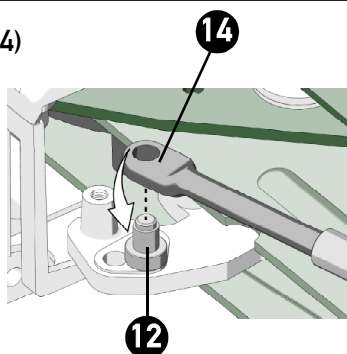

8 Assembler la plaquette (15) dans la direction montrée dans la figure et la bloquer en vissant la vis (16) sur le trou du pivot (17) du balancier.

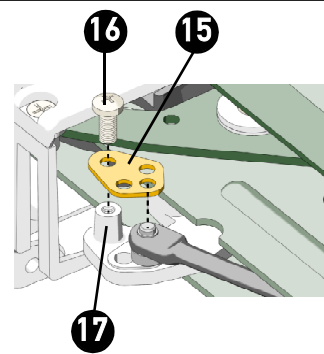

⚠ AVERTISSEMENT

Vérifier le réglage correct de la course de l'inverseur et s'assurer que la condition suivante soit respectée: Pendant l'insertion de l'inverseur le mouvement du levier doit être toujours fluide, son résistance doit être constante et il ne doit rencontrer aucune résistance en continuant à tourner le levier lui-même en fonction d'accélérateur. Dans le cas contraire contrôler la correspondance de la course entre commande et inverseur sur le moteur.



1.3.2 Connexion du câble pour le contrôle du gaz

1 Enlever la butée de gaine (7) de la plaque (8) en dévissant les vis (9).

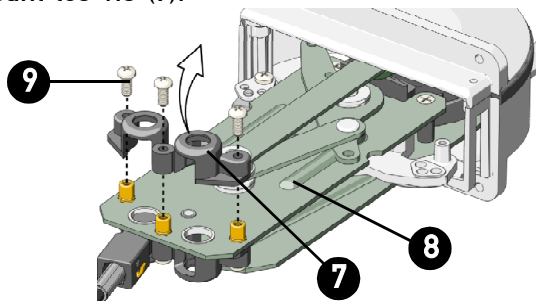

2 Positionner le câble de sorte que l'élément cylindrique du connecteur (10) soit positionné à l'intérieur du trou (18) de la plaque.

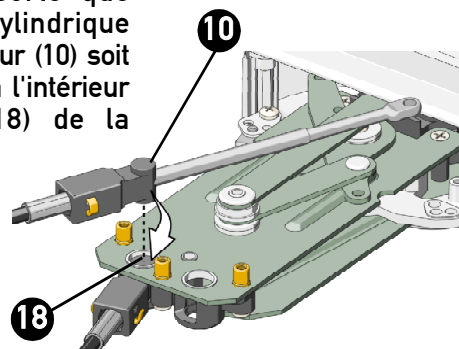

3 Repositionner la butée de gaine (7) sur la plaque (8) en alignant l'élément cylindrique du connecteur (10) au trou de la butée de gaine. Fixer la butée de gaine à la plaque en serrant les trois vis (9).

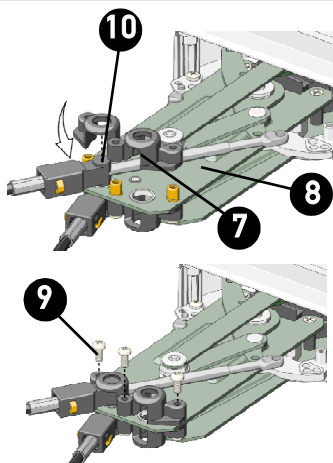

4 Insérer la tige (19) dans le pivot (20).

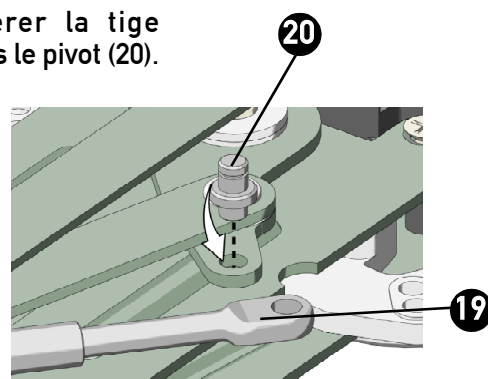

5 Fixer le câble à l'aide de l'anneau élastique (21) qui doit être inséré dans le logement adéquat obtenu sur le pivot (20).

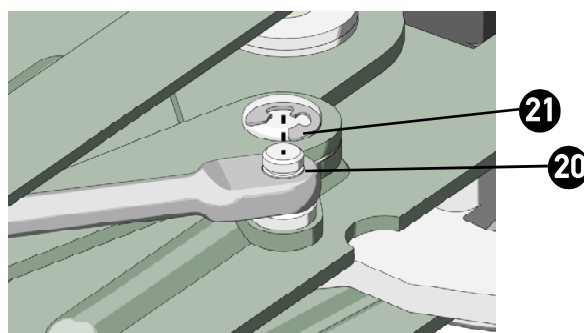

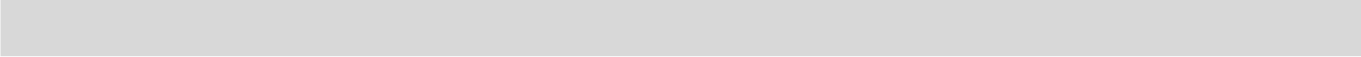

ULTRAFLEX S.p.A.

16015 Casella (Genova) Italia - Via Crose, 2

